

Optics and Laser Heads for Laser-Interferometer Positioning Systems

Product Overview

Choose from a large selection of optical components
for system design flexibility

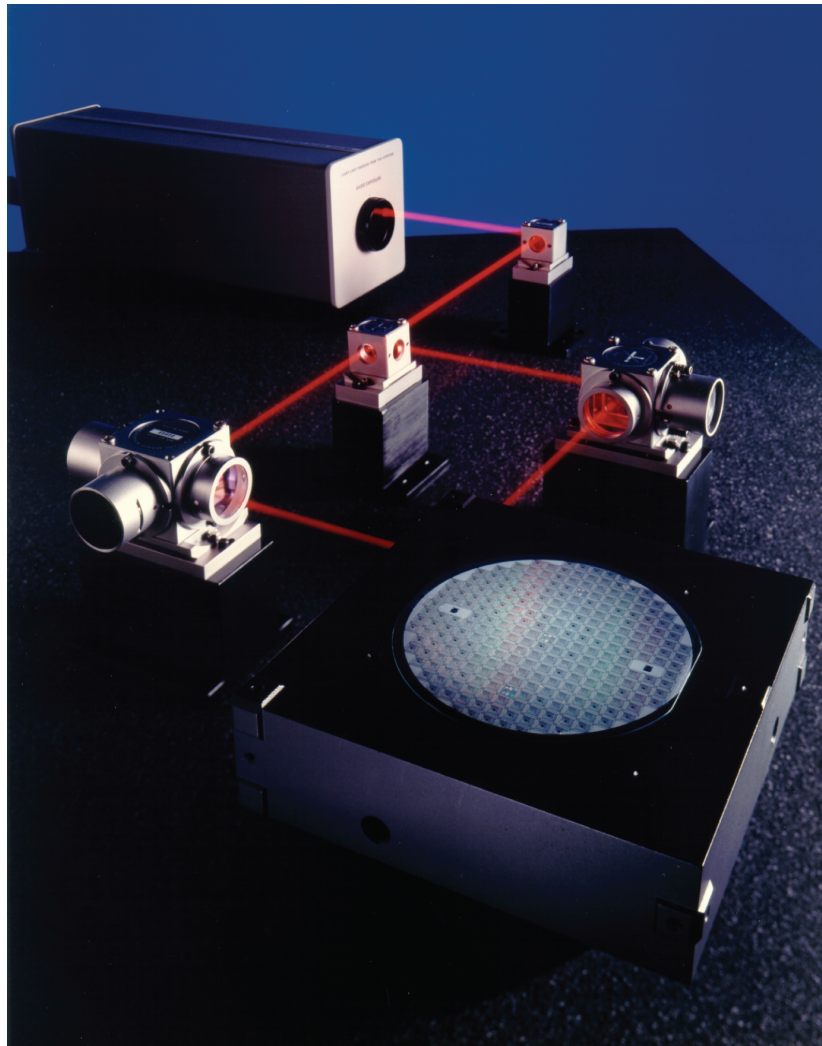

Agilent Technologies

Table of Contents

3	Design Your System for Peak Performance
4	Laser Head Specifications
6	Directing Optics Specifications
8	Measurement Optics Specifications
8	Linear Optics
9	Single Beam Optics
10	Plane Mirror Optics
12	Differential Interferometer
14	Multiaxis Optics
22	Wavelength Tracker
23	Accessory Specifications
24	Receiver Specifications
26	Optics and Laser Head Configuration Guide
28	Example Configurations

How to Use This Product Overview

This product overview provides details on the laser heads, receivers, and optics used by all Agilent Technologies laser interferometer positioning systems. Together with the electronics information contained in companion data sheets, this information will enable you to specify your entire laser positioning system. Select from the following companion data sheets:

- Agilent 5527B Laser Interferometer Positioning System
- High Performance Laser Interferometer Positioning Systems for VMEbus
- Complete, PC-compatible, Closed-loop Laser Positioning

Design Your System for Peak Performance

The wide variety of optics and laser heads from Agilent gives you maximum design flexibility to achieve your performance goals.

In addition to a full range of conventional optics, multi-axis optics provide new possibilities for extremely accurate positioning system designs. Several laser heads offer different sizes and axis velocities to meet your requirements. Remote receivers with fiber-optic pickups allow maximum layout flexibility while removing electronics heat from the measurement area for superior repeatability. Optical wavelength tracking also assists you in achieving unsurpassed measurement repeatability.

This product overview covers laser head specifications. Then, the major part of the product overview is devoted to the many optics Agilent has developed for directing the laser beam and making a wide variety of measurements. Accessories and receivers are covered next. Finally, an extensive configuration guide illustrates a number of optical layouts for specific applications. These examples are provided to help you design an optical layout that meets your measurement needs.

Configuring Your System

All laser-interferometer positioning systems use a laser head, optics, and electronics. After investigating the choices in this product overview and its companion electronics data sheets, you can configure your system by:

1. First choosing a backplane based on the other system electronics you want to use or the outputs you need,
2. then choosing a laser head based on size and velocity requirements,
3. selecting the optics that best match your application needs, and
4. finally, selecting the environmental compensation that meets your accuracy needs.

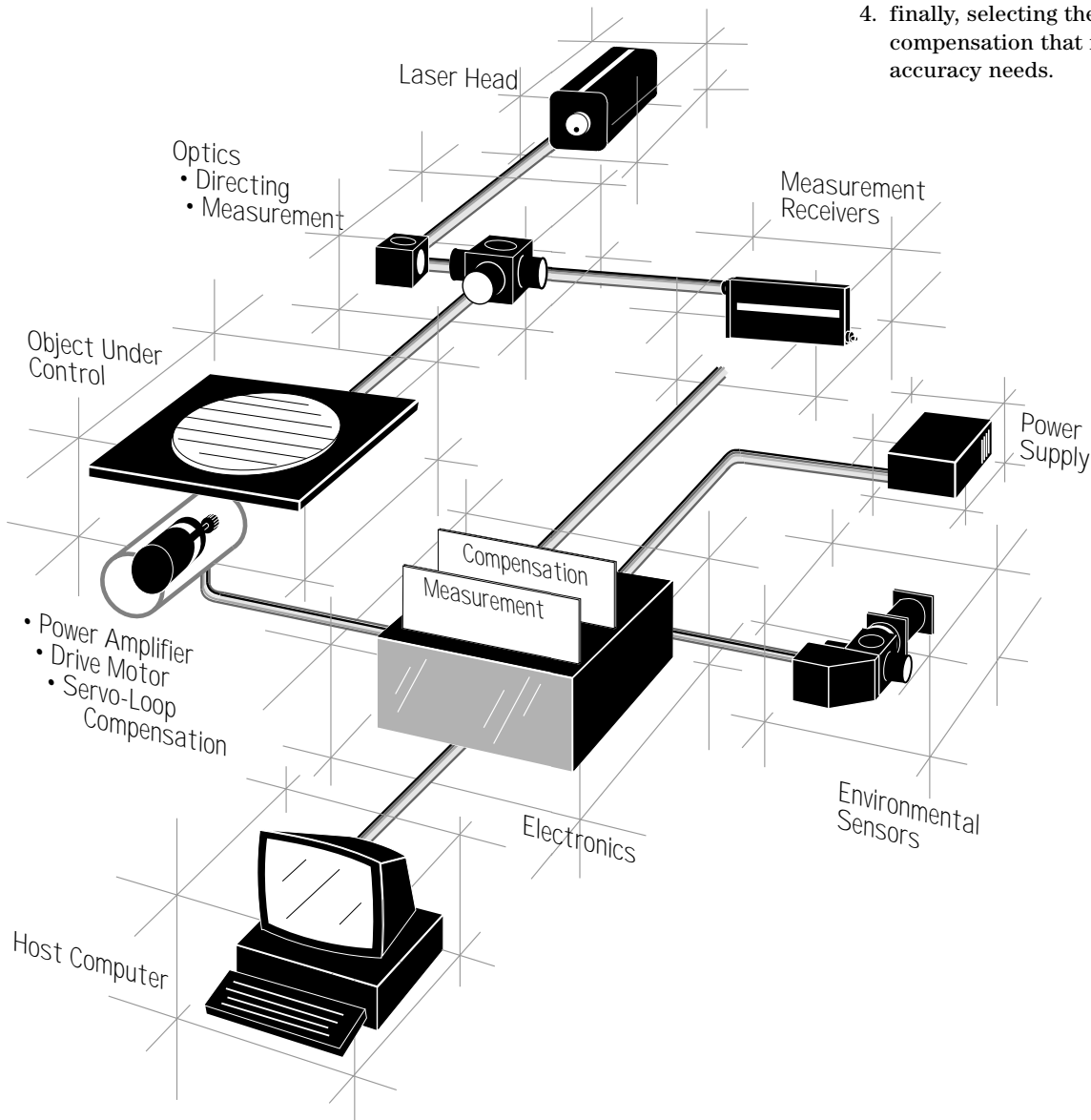

Laser Head Specifications

Four laser heads are available for different size, velocity, and interface requirements.

The Agilent 5517 series of laser heads provides choices for all available size and velocity requirements in a consistent interface. The 5517A is the basic laser head. The 5517B offers 25% greater axis velocity in a smaller package. The 5517C offers still higher velocity, 75% higher than the 5517A. The 5517D offers the highest axis velocity and is the same size as the 5517B.

Standard beam diameter is 6 mm. In addition, there are two beam size options available for the 5517C. Option 003 provides a 3-mm beam diameter for use with the Agilent 10719A and 10721A differential interferometers and 10737L/R compact three-axis interferometers. Option 009 provides a 9-mm beam diameter for use with the 10735A and 10736A three-axis interferometers. The larger beam allows these interferometers a larger angular range of measurement.

Finally, the Agilent 5501B laser head is available to replace the previous 5501A laser head in existing applications that require the same polarization, cabling, and electrical power as the 5501A. The 5501B also offers improved accuracy, reliability, and serviceability compared to the previous 5501A.

All laser heads use a proven long-life laser tube with a demonstrated Mean Time Between Failure greater than 50,000 hours of operation, making them the most reliable lasers of their type available.

Agilent 5501B and 5517A/B/C/D Laser Heads

Physical Characteristics

Weight:

5517A: 5.5 kg (12 lb)
5517B/C/D: 3.4 kg (7.5 lb)
5501B: 3.4 kg (7.5 lb)

Warm-Up Time: less than 10 minutes (5 minutes typical)

Magnetic Field Strength (Non-Operating): Does not exceed 5.25 milli-Gauss at a distance of 4.6 m (15 ft) from any point on the surface of the packaged Laser Head.

Clearance required for cabling:

5517A: 12.0 cm (4.72 in)
beyond back of unit
5517B/C/D: 10.16 cm (4.0 in)
beyond back of unit
5501B: 7.5 cm (3.0 in)
beyond back of unit

Power

Power Requirements:

(5517A)
+15V \pm 0.3V at 2.5A max
-15V \pm 0.3V at 0.02A max
(5517B/C/D)
+15V \pm 0.3V at 2.2A max
-15V \pm 0.3V at 0.02A max
(5501B)
+15V \pm 0.3V at 0.79A max
-15V \pm 0.3V at 0.67A max

Power Dissipation (nominal):

Warm-Up: 35W (5517A/B/C/D)
Operation: 23W (5517A/B/C/D)
Maximum: 21.9W (5501B)

Laser Characteristics

Type: Helium-Neon, Continuous Wave, Two-Frequency

Minimum Beam Power Output: 180 μ W

Maximum Beam Power Output: 1 mW

Std. Beam Diameter: 6 mm (0.25 in) typical

5517C Opt 003: 3 mm (0.125 in)

5517C Opt 009: 9 mm (0.375 in)

Vacuum Wavelength Accuracy

(3 σ , lifetime):

\pm 0.1 ppm (\pm 0.02 ppm with factory calibration to MIL-STD 45662)

Nominal Vacuum Wavelength:

632.991372 nm (5501B, 5517A/B)

632.991354 nm (5517C/D)

Vacuum Wavelength Stability (one hour):

\pm 0.002 ppm typical

Vacuum Wavelength Stability (lifetime):

\pm 0.02 ppm typical

Safety Classification:

Class 2 Laser Product conforming to U.S. National Center for Devices and Radiological Health Regulations 21 CFR 1040.10 and 1040.11.

Reference Frequency:

5517A: 1.5–2.0 MHz

5517B: 1.9–2.4 MHz

5517C: 2.4–3.0 MHz

5517D: 3.4–4.0 MHz

5501B: 1.5–2.0 MHz

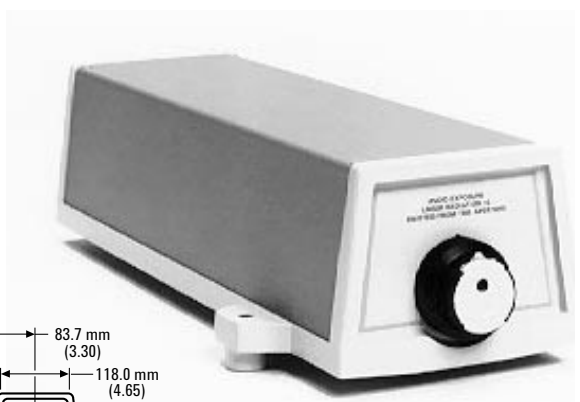
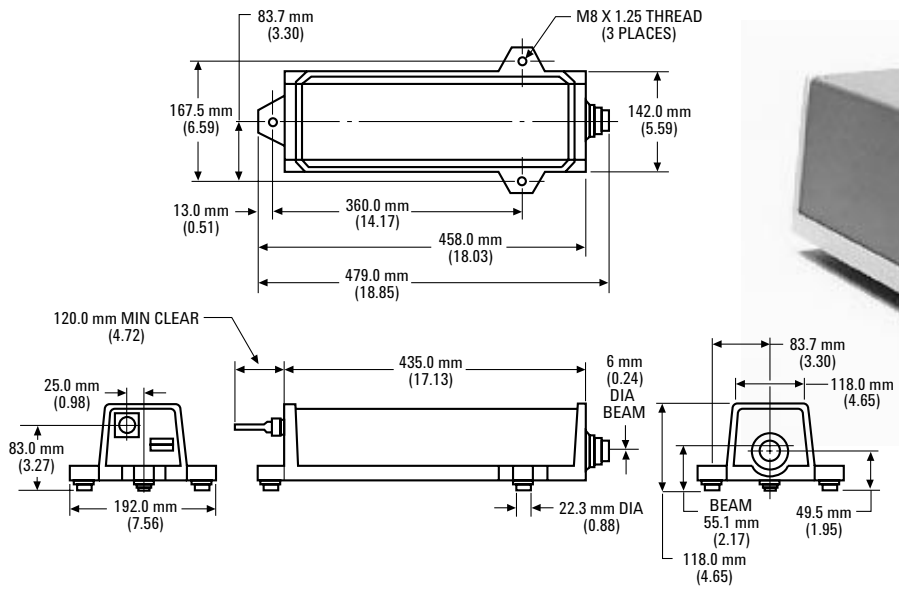

Agilent 5517A

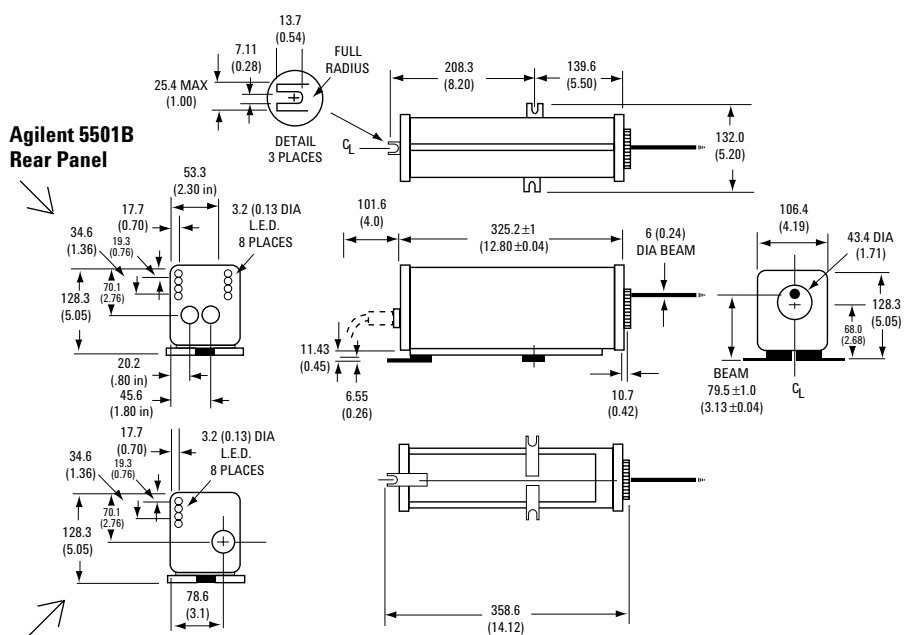

**Agilent 5501B
Rear Panel**

**Agilent 5517B/C/D
Rear Panel**

Agilent 5501B, 5517B, 5517C, 5517D



Note: Dimensions of all drawings in this product overview are given in millimeters, with corresponding dimensions in inches given in parentheses.

CAUTION

LASER LIGHT

DO NOT STARE INTO BEAM

MAXIMUM OUTPUT 1mw
 PULSE SPEC continuous wave
 LASER MEDIUM helium neon
 CLASS II LASER PRODUCT

Directing Optics Specifications

A variety of beam splitting and directing optics allows maximum flexibility in optical layouts. Unless otherwise noted, all optics are designed for beam diameters of 6 mm or less. These optics all have housings for standard mounting techniques.

Beams of 9-mm diameter can be used with the Agilent 10735A/10736A to provide greater angular range. For directing 9-mm beams, the 10725A, 10726A, and 10728A must be used. These are bare optics that require user-supplied mounts.

10700A 33% Beam Splitter

Use: Reflects $\frac{1}{3}$ of the total incoming laser beam, transmits $\frac{2}{3}$

Weight: 62 g (2.2 oz)

10701A 50% Beam Splitter

Use: Reflects $\frac{1}{2}$ of the total incoming laser beam, transmits $\frac{1}{2}$

Weight: 62 g (2.2 oz)

10707A Beam Bender

Use: Bends incoming beam at a 90° angle

Weight: 58 g (2.1 oz)

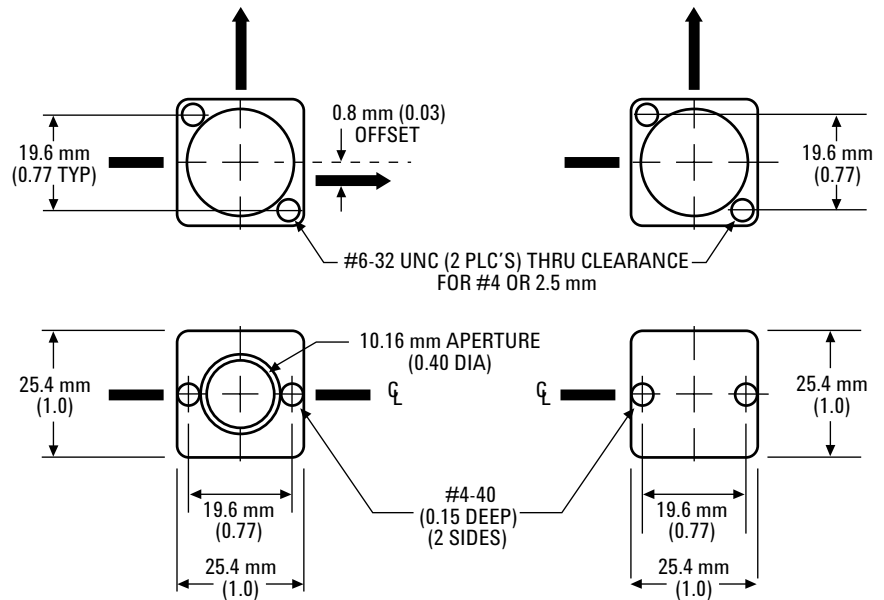

10567A Dual Beam Beam Splitter

Use: 50% beam splitter which allows both of the split beams to return through the splitter parallel to the incoming beam. Useful when it is necessary to minimize the number of optical ports (for example in a vacuum chamber), or when both receivers must be mounted in the same area.

Weight: 317 g (11.3 oz)

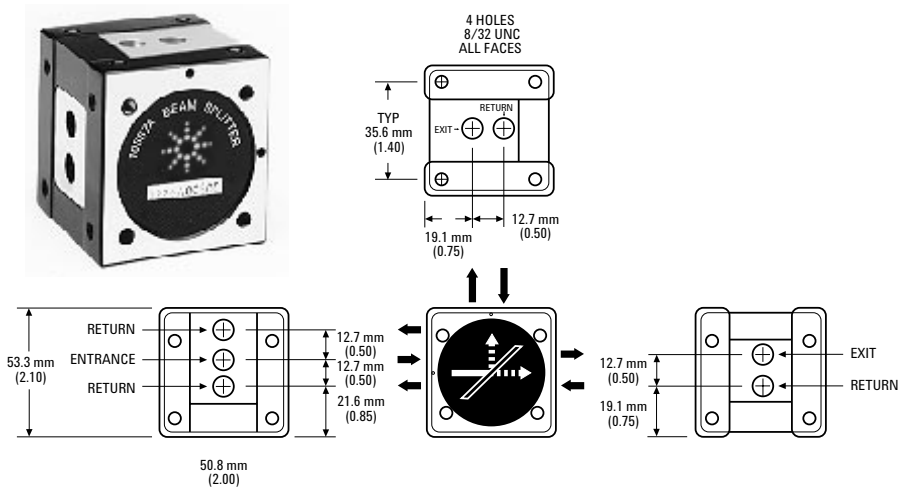

10725A 9-mm Laser Beam Splitter

Use: 50% beam splitter; divides the beam into equal parts, transmits one part straight through and bends the other part at a 90 degree angle. It is designed for use with beams of 9-mm diameter and smaller. This bare optic requires a user-supplied mount.

Weight: 2 g (0.07 oz)

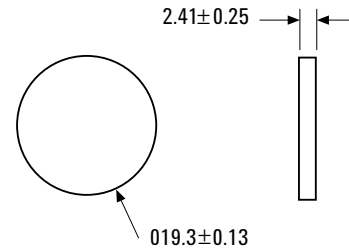

10726A 9-mm Laser Beam Bender

Use: Bends incoming beam at a 90 degree angle. Like the 10725A, it is designed for use with beams of 9-mm diameter and smaller and is a bare optic that requires a user-supplied mount.

Weight: 10 g (0.35 oz)

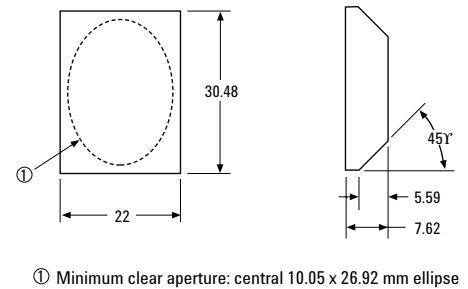
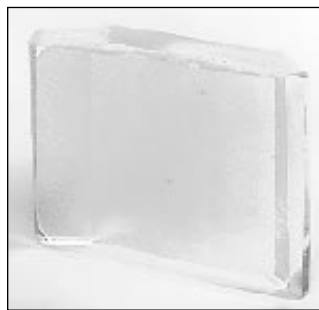

10728A 9-mm Laser Beam Plane Mirror

Use: Normal incidence plane mirror. Like the 10725A, it is designed for use with beams of 9-mm diameter and smaller and is a bare optic that requires a user-supplied mount.

Weight: 21 g (0.74 oz)

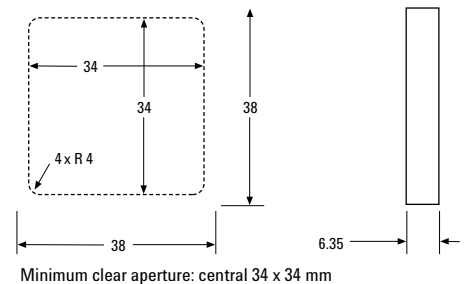
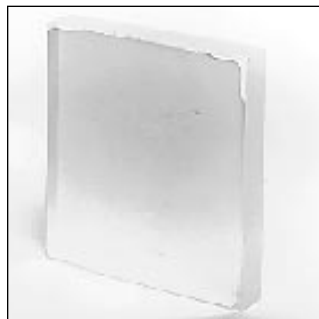

Measurement Optics Specifications

A variety of optics allows maximum measurement flexibility. Unless otherwise noted, all optics are designed for beam diameters of 6 mm or less.

The Agilent 10702A Linear Interferometer is the basic interferometer for linear measurements, while the small 10705A Single-beam Interferometer is designed for use in confined spaces.

For multiaxis stages, plane mirror interferometers such as the Agilent 10706B are commonly used (see pages 10 and 11). The 10716A high-resolution plane-mirror interferometer provides

twice the resolution of the 10706B for the most precise applications (see page 13). The 10715A is a plane-mirror interferometer designed for differential measurements (see page 12). The 10724A Plane Mirror Reflector may be used with these plane mirror interferometers for single-axis measurements (see page 11).

The Agilent 10719A one-axis and 10721A two-axis differential interferometers are designed to optimize the accuracy and repeatability of IC-fabrication equipment by referencing the position of the wafer stage

directly to the optics column. The Agilent 10735A and 10736A three-axis interferometers make three measurements simultaneously (linear, yaw, and pitch or roll) for precise wafer positioning in IC-fabrication equipment and other precision stage applications. See pages 14 through 21 for details on these optics.

The Agilent 10717A Wavelength Tracker monitors changes in the index of refraction of air to optically compensate for environmental changes (see page 22).

Linear Optics

10702A Linear Interferometer

Use: For general-purpose, single-axis measurements. If the interferometer is the moving component, then 10702A Opt. 001 Windows MUST be ordered, and the interferometer cannot be used to bend the beam.

Weight:

10702A: 232 g (8.2 oz)

10702A Opt. 001: 246 g (8.7 oz)

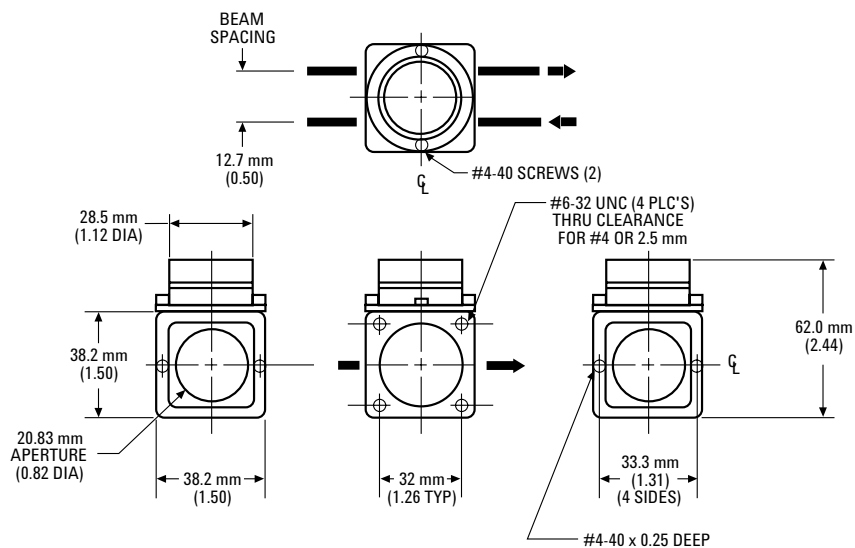

10703A Reflector

Use: Paired with 10702A (or 10702A Opt. 001) Linear Interferometer. Cube corner reflector simplifies alignment. If mass is extremely critical, this component is available without housing (10713B). Weight of the bare cube corner is 11.4 g (0.4 oz).

Weight: 42 g (1.5 oz)

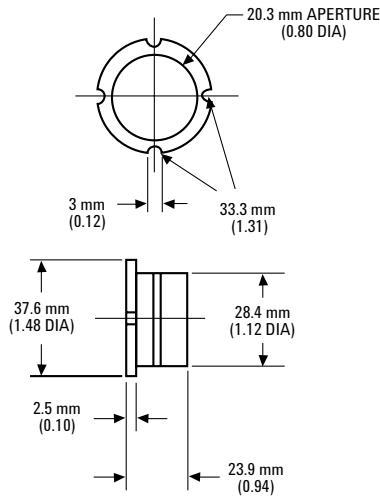

Single Beam Optics

10704A Reflector

Use: Paired with the 10705A Single Beam Interferometer. Cube corner reflector simplifies alignment. If mass is extremely critical, this component is available without housing (10713C). Weight of the bare cube corner is 1.4 g (0.05 oz).

Weight: 10.5 g (0.4 oz)

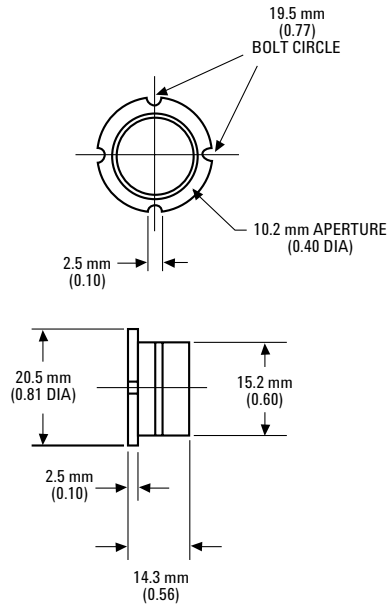

10705A Single Beam Interferometer

Use: Low mass/limited space single-axis measurements such as disk-drive applications. Can be used to bend the beam, but cannot be used as the moving component.

Weight: 85.5 g (3 oz)

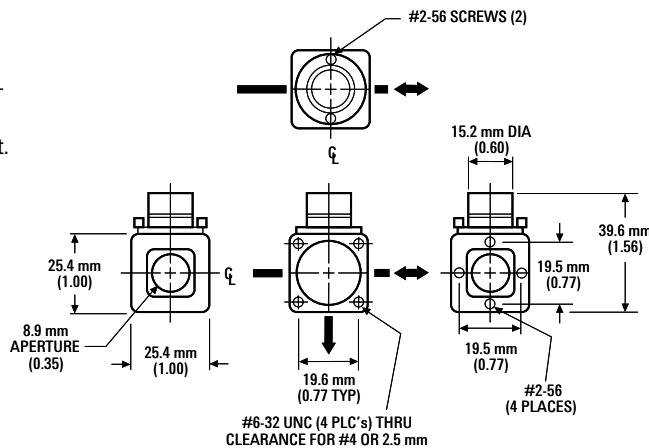

Measurement Optics Specifications, continued

Plane Mirror Optics

10706B High-Stability Plane Mirror Interferometer

Use: Multiple axis applications such as X-Y stage. Can be used to bend the beam, but cannot be used as the moving component. This thermally stable optic is an exact functional replacement for the 10706A Plane Mirror Interferometer. The 10706B design improves measurement stability during temperature changes that affect the optics by reducing measurement drift to $\frac{1}{12}$ the value typically achieved by conventional plane-mirror interferometers such as the 10706A.

Weight: 323 g (11.4 oz)

Thermal Drift Coefficient (Change of indicated distance per °C temperature change): 0.04 $\mu\text{m}/^\circ\text{C}$ (1.6 $\mu\text{in}/^\circ\text{C}$) typical. Other specifications same as 10706A.

Typical Measurement Mirror Alignment Requirements for 10706A and B (as a function of distance):

- 152 mm (6 in): ± 6 arc-min from normal
- 305 mm (12 in): ± 3 arc-min from normal
- 508 mm (20 in): ± 1.5 arc-min from normal

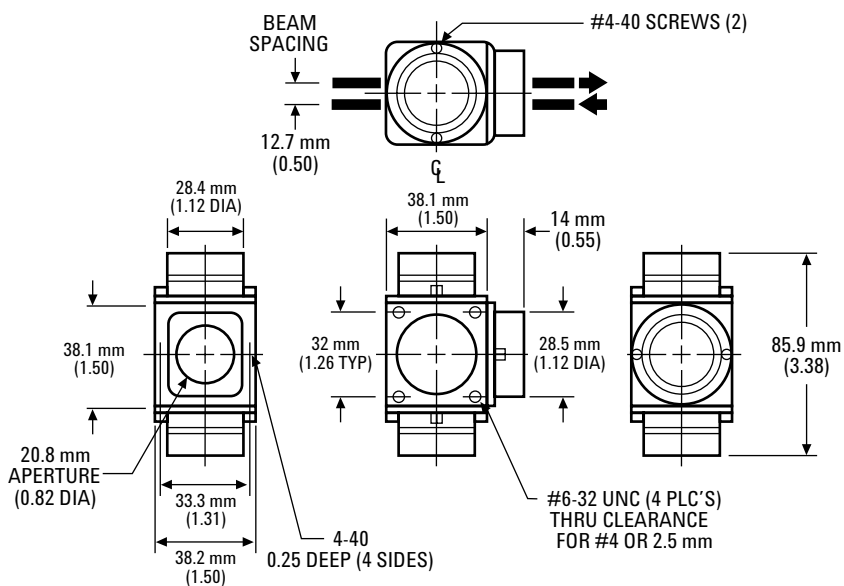

Interferometer Thermal Drift

This plot shows the measurement drift during optics temperature changes for a conventional plane-mirror interferometer compared with the 10706B High Stability Plane Mirror Interferometer, the 10715A Differential Interferometer, and the 10716A High Resolution Interferometer. The 10706B is nearly as stable as the more expensive 10715A and far more stable than the conventional plane-mirror interferometer. The 10716A has the same stability as the 10706B with two times better resolution. For example, with $\pm 0.5^\circ\text{C}$ temperature control, measurement drift with the 10706B and 10716A is typically ± 0.02 microns ($\pm 0.8 \mu\text{in}$) compared with ± 0.25 microns ($\pm 10 \mu\text{in}$) with a conventional plane-mirror interferometer.

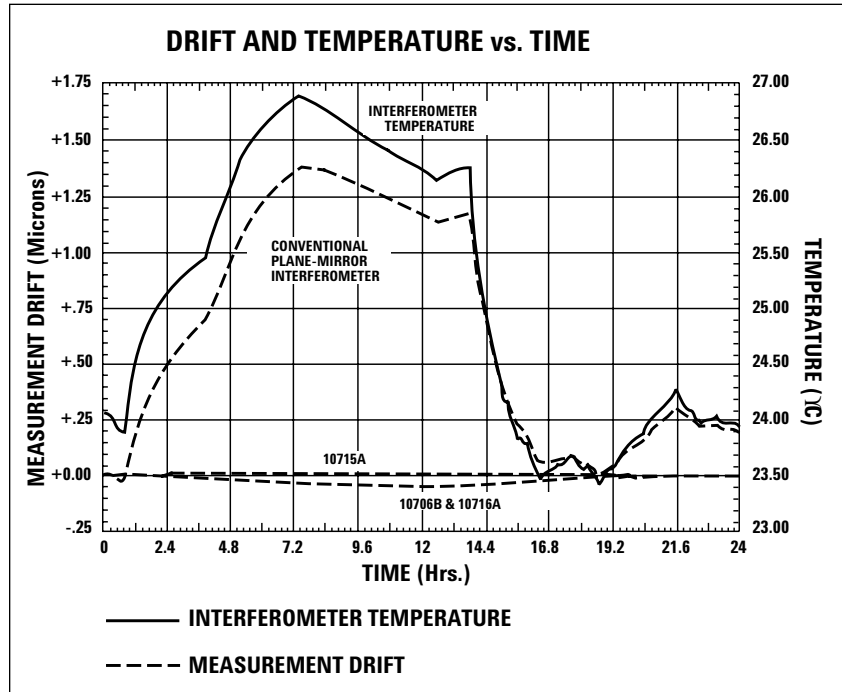

10724A Plane Mirror Reflector

Use: This reflector may be used with the 10706A and B, 10715A, and 10716A interferometers for single-axis measurements.

Weight: 50 g (1.8 oz)

Adjustment Range: $\pm 1^\circ$ (Alignment hardware included)

Reflectance: 98% at normal incidence



Recommended Plane Mirror Specifications (for 10706A and B, 10715A, and 10716A reflectors)

Reflectance: 98% at 633 nm at normal incidence

Flatness: Flatness deviations will appear as measurement errors when the mirror is scanned perpendicular to the beam. Recommended range is $\lambda/4$ ($0.16 \mu\text{m}$ or $6 \mu\text{in}$) to $\lambda/20$ ($0.03 \mu\text{m}$ or $1.2 \mu\text{in}$) dependent on accuracy requirements.

Optical Surface Quality: 60–40 per Mil 0-13830

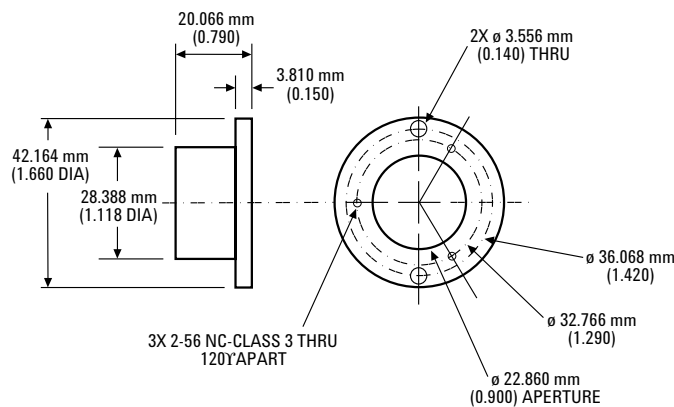

Measurement Optics Specifications, continued

Differential Interferometer

10715A Differential Interferometer

Use: Performs differential measurements between the supplied reference mirror and a measurement plane mirror. Provides the best long-term stability of any plane mirror interferometer in plane mirror applications. Minimizes deadpath. The Agilent 10715A eliminates thermal drift in measurements because the entire optical path through the interferometer is common mode. Alignment is slightly more complex than the 10706A/B.

For optical layouts requiring the interferometer to turn the beam, the 10715A Opt. 001 must be used.



Weight:

Interferometer: 594 g (1.31 lb)
Reference Mirror: 3.2 g (0.1 oz)

Typical Measurement and Reference Mirror Alignment Requirements

(as a function of distance):
±2.5 arc-min for 152 mm (6 in)
±1.3 arc-min for 305 mm (12 in)
±0.7 arc-min for 508 mm (20 in)

For complete dimensions see drawing on next page.

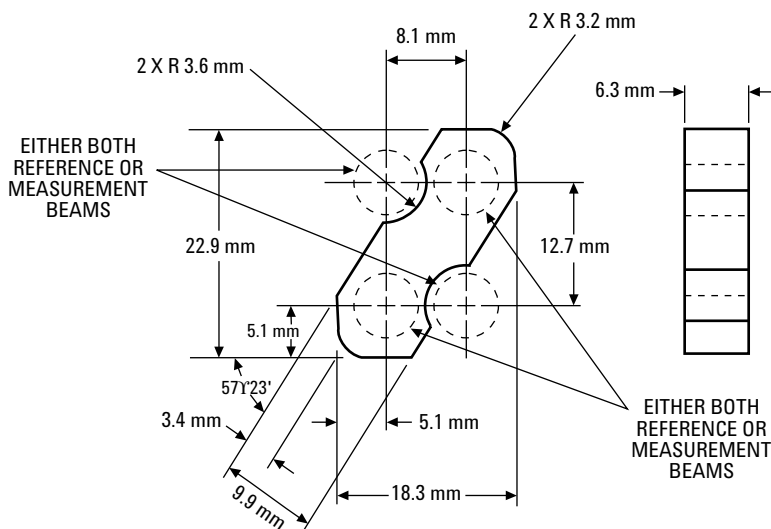

PART NUMBER: 10715-20205
WEIGHT: 3.2 GRAMS

Reference Mirror for Agilent 10715A

10716A High Resolution Interferometer

Use: Single and multiple axis high resolution applications such as precision X-Y stages. The Agilent 10716A High Resolution Interferometer improves the system measurement accuracy and repeatability by providing two times better measurement resolution along with the same thermal stability as the 10706B.

For optical layouts requiring the interferometer to turn the beam, the 10716A Opt. 001 must be used.

Weight: 502 g (1.11 lb)

Thermal Drift Coefficient (Change of indicated distance per °C temperature change):
0.04 μm/°C (1.6 μin/°C) typical

Typical Measurement Mirror Alignment Requirements:

Depends on the distance between the interferometer and plane mirror. Typical mirror pitch/yaw angles are:

- ±6 arc-min for 152 mm (6 in)
- ±3 arc-min for 305 mm (12 in)
- ±2 arc-min for 508 mm (20 in)

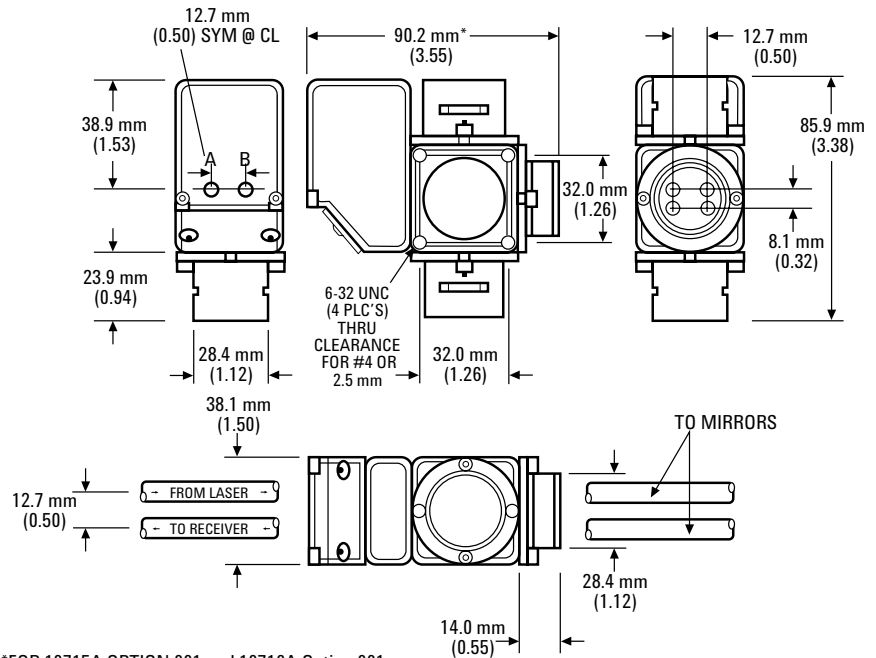

*FOR 10715A OPTION 001 and 10716A Option 001
THIS DIMENSION IS 100.1 mm (3.94)

Agilent 10715A and 10716A

Measurement Optics Specifications, continued

Multiaxis Optics

Improve Positioning Accuracy for Sub-0.5-micron Lithography and Other Applications

Agilent offers three styles of multiaxis interferometers that make linear and angular measurements. This gives you greater control of multiaxis stages and allows better overall system accuracy.

Each style is available in two models. These six interferometers provide linear and angular measurements for up to five degrees of stage freedom (X, Y, pitch, roll, and yaw). This gives you the capability to measure and position an object with higher precision than linear measurements alone. Finer linewidths in ICs and more accurate parts can result from the additional angular measurement and control available with these interferometers.

The Agilent 10719A and 10721A perform one- and two-axis differential measurements respectively. Differential measurements provide highly accurate position information using an object such as an optical column as a position reference. This reduces system errors in those applications.

The Agilent 10737R, 10737L, 10735A, and 10736A each perform three measurements, one linear and two angular. These three measurement paths have built-in interaxis alignment to give high system accuracy. The 10737R and 10737L use a 3-mm laser beam for a compact optic package. The 10735A and 10736A can use a 9-mm laser beam to provide the widest angle range available.

Increase system accuracy and reduce costs

- **Maximize system accuracy.** Multiaxis optics provide measurement and control of stage rotations for improved overlay accuracy.
- **Maximize thermal stability.** Monolithic optics and equal glass path lengths minimize errors due to thermal drift.
- **Maximize mechanical stability.** Monolithic optics provide tight interaxis coupling and minimize errors due to vibration.
- **Minimize error due to interaxis misalignment.** Optical design provides guaranteed interaxis parallelism, no longer dependent on installation.
- **Lower installation costs.** Referenced optics, kinematic installation, pre-aligned fiber-optic receiver mounts, and no interaxis adjustments make installation easy.
- **Lower manufacturing costs.** Multiaxis optics reduce the number of components to install.
- **Lower service cost.** Fiber-optic receivers are mounted in a convenient location, and Agilent multi-axis interferometers are easy to remove or install.

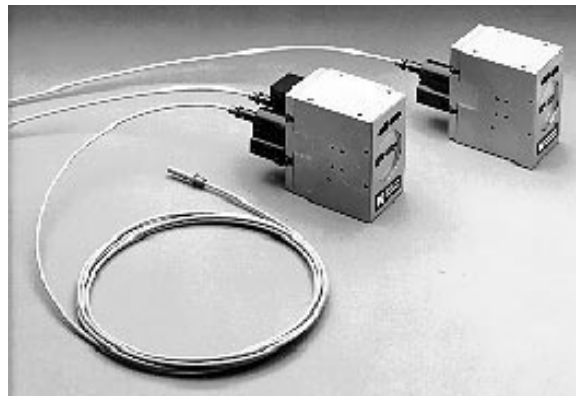

Agilent 10719A and 10721A



Agilent 10735A and 10736A Option 001

Applications

- *Lithography*
- *Precision machining*
- *Advanced metrology*
- *R & D on multiaxis stage control*
- *Stage travel characterization*
- *Stage or tool alignment*

Multiaxis measurements allow smaller linewidths, wider fields, and higher throughputs

Small linewidths and stage motion errors due to imperfect ways generally require state-of-the-art wafer steppers to control rotational misalignment about the Z axis (Yaw). This has typically been done with two discrete interferometers that require careful alignment during installation.

Agilent now offers multiaxis interferometers that make linear and rotational measurements in a single compact package, conserving valuable space. The interferometers were designed for excellent built-in parallelism, providing an interaxis alignment superior to a careful alignment of discrete interferometers. This helps improve the grid accuracy needed for smaller linewidths.

Internal optics are referenced to their housings, allowing the interferometers to be kinematically located, then bolted into a precision mount without adjustment. Built-in parallelism and referenced optics save the manufacture and service time due to difficult multiaxis alignments. These features also help achieve better overlay accuracy than typically possible with discrete interferometers.

Pitch and roll measurements enhance wide field optical lithography

To reduce linewidths, optical lithography systems such as i-line and deep UV are moving toward larger numerical apertures. The shallower depth of field resulting from a larger numerical aperture can require site-by-site wafer leveling about the X and Y axis (pitch and roll) to achieve focus over a wide field. Unfortunately, X-Y alignment accuracy suffers because the Abbé error, neutralized during the global alignment, changes during wafer leveling.

Agilent multiaxis interferometers can measure the pitch and roll of the multi-axis stage due to leveling and stage movement errors, making it possible to calculate and compensate for the change in Abbé error. The quick correction saves the time of performing a site-by-site alignment, thus improving throughput.

Mirror mapping improves multiaxis stage performance

The yaw of a multi-axis stage is measured using a two- or three-axis interferometer located on either the X or Y axis. When yaw is measured redundantly (on both the X and Y axes), the system has the additional capability of mirror mapping. Mirror mapping allows you to measure and compensate the flatness deviations in the stage mirrors. This improves total system accuracy.

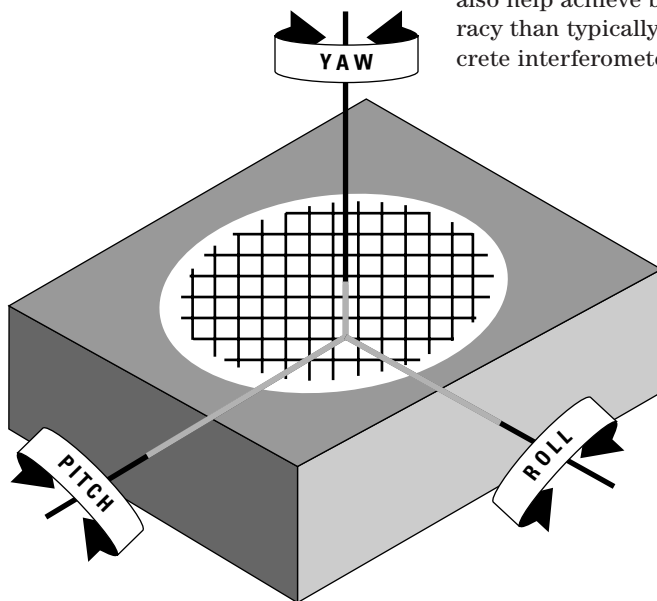

Multiaxis interferometric measurements of stage angles enhance the accuracy and throughput of fine-line, wide-field lithography systems.

Measurement Optics Specifications, continued

The 10719A and 10721A allow column-referenced measurements

The Agilent 10719A and 10721A One-axis and Two-axis Differential Interferometers measure the linear distance between two objects, instead of the distance between the interferometer and an object. This offers a high degree of immunity to unwanted interferometer displacement such as the thermal expansion between the optical column and the interferometer. Errors common to the reference and measurement path are removed because both are equally affected. This improves overlay accuracy in some lithography systems. The Abbé offset error is also decreased by using a small 3-mm beam.

Both interferometers are modular and compact, making it easier to build customized measurement systems with one to six axes.

The 10719A makes either a differential linear or angular measurement. The linear measurement gauges the displacement between two objects such as an optical column and a stage. Alternatively, the 10719A measures either pitch or roll.

The 10721A simultaneously performs two differential measurements, linear and angular (yaw) displacement. Both measurements reference an external mirror mounted to an object such as a column.

Column referencing enhances semiconductor inspection

Mask and IC inspection typically require the stage to be moved linearly by small increments with respect to an inspection instrument such as a microscope. This is required in order to compare a desired image with the newly created image. The 10719A was designed to make linear measurements referencing an object such as an inspection tool.

X-ray systems benefit from column referencing

X-rays provide finer linewidth lithography because the wavelengths are shorter than optical wavelengths. Slight yaw misalignment reduces the capability even more in these systems than optical lithography systems, because of the finer linewidths. A method to achieve the required accuracy is to reference the multiaxis stage movement to the mask holder. The 10719A and 10721A have been optimized to perform these measurements.

Additional features that increase accuracy and decrease cost

- *Monolithic optics*
- *Guaranteed interaxis parallelism*
- *Prealigned fiber-optic remote receiver mounting*
- *Referenced optics*
- *Kinematic Installation*

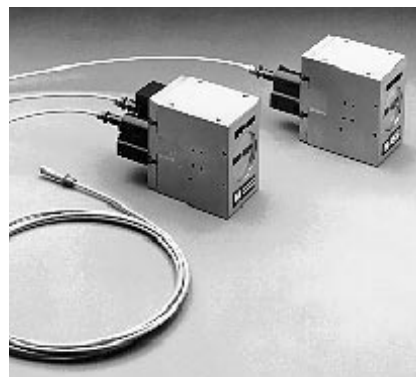

Improve overlay accuracy with the Agilent 10719A/10721A by referencing the image-making column.

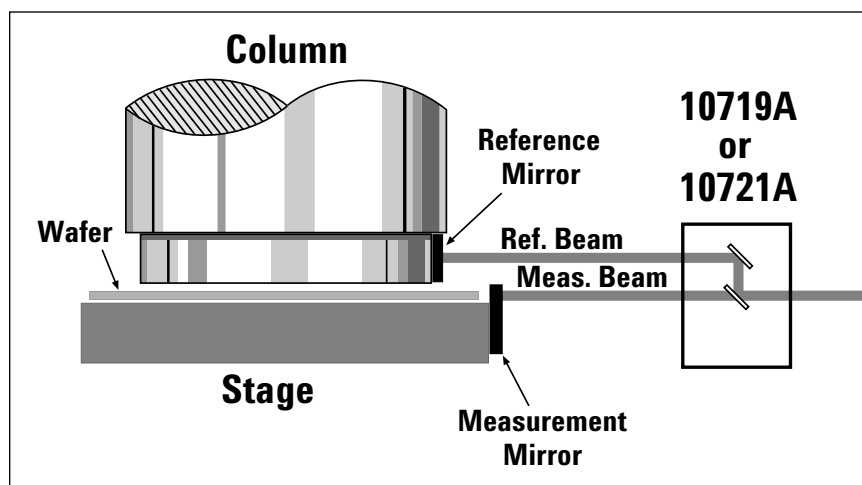

10719A One-axis Differential Interferometer

Use: Single- and multiple-axis applications where the stage must be linearly positioned with respect to an external object such as a column or inspection tool. Alternatively, an angle is measured when both reference and measurement beams measure to the same mirror.

Specifications

Weight: 300 g (11 oz)
 Axes: Linear, pitch, or roll
 Available Beam Size: 3 mm
 Thermal Drift Coefficient (Average):
 150 nm (5.9 μ m) /°C

Resolution*

Linear: 0.6 nm
 Pitch/roll: 0.03 μ rad (0.007 arc-sec)
Angular Range** (at 300 mm):
 Pitch/roll: \pm 0.44 mrad (\pm 1.5 arc-min)

Parallelism (Input to output beams):
 <0.1 mrad (20 arc-sec)

10721A Two-axis Differential Interferometer

Use: Multiaxis applications where the stage must be positioned linearly and angularly with respect to an external object such as a column or inspection tool.

Specifications

Weight: 300 g (11 oz)
 Axes: Linear and yaw
 Available Beam Size: 3 mm
 Thermal Drift Coefficient (Average):
 150 nm (5.9 μ m) /°C

Resolution*

Linear: 0.6 nm
 Yaw: 0.05 μ rad (0.01 arc-sec)
Angular Range** (at 300 mm):
 Yaw: \pm 0.44 mrad (\pm 1.5 arc-min)

Parallelism (Input to output beams):
 <0.1 mrad (20 arc-sec)

10719A/10721A Installation Requirements/Recommendations

Installation and Alignment: Kinematic installation requires a referenced surface. See "Laser and Optics Users Manual" for complete installation procedure.

Interaxis Alignment: All internal optics are referenced to mounting surface and prealigned.

Receivers: Agilent 10780F fiber optic remote receivers.

Receiver Alignment: Self aligning when mounted to interferometer.

Measurement and Reference (Plane)

Mirror Recommendations: Same as 10706A/B; see page 11.

NOTE: Flatness deviations will appear as measurement errors when the mirror is translated across the beam. The mirror mount should not bend the mirror. If accuracy requirements demand it, mirror flatness may be calibrated (scanned and stored in the system controller) to be used as a correction factor.

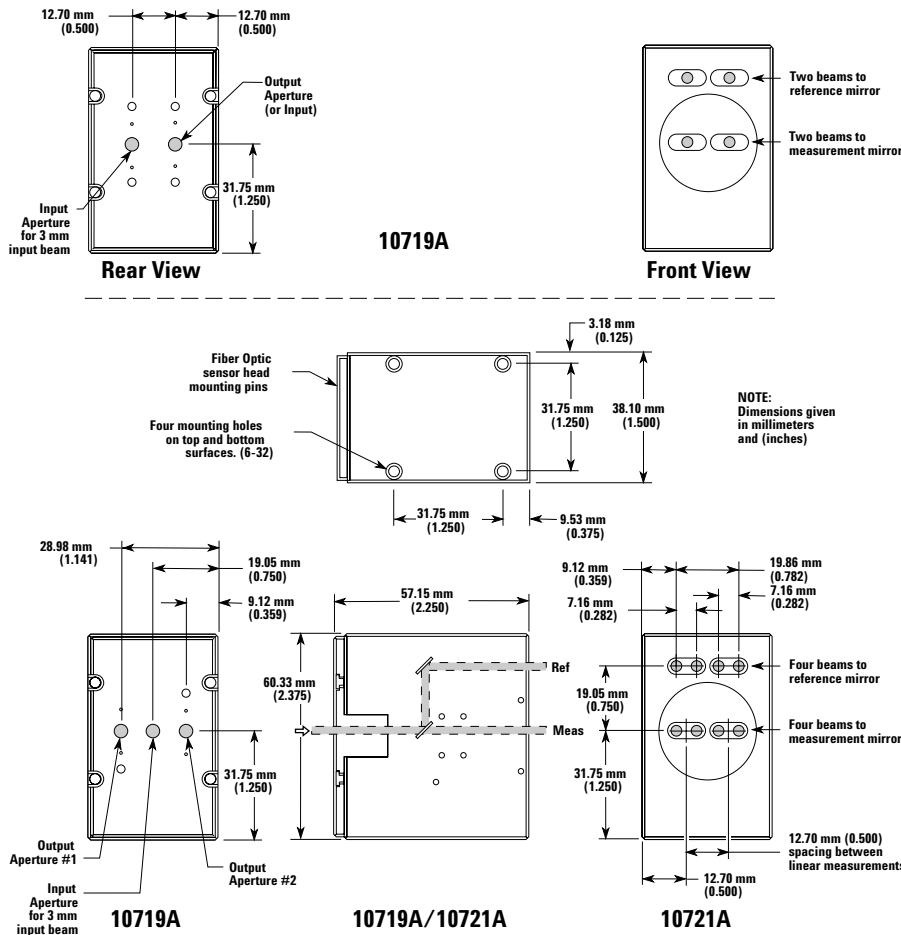

* Resolution is dependent on the electronics used. These specifications are for the 10897B electronics.
 ** Angular range is the maximum measurement mirror angle due to all components (i.e., yaw and pitch or yaw and roll) between the measurement mirror and the interferometer for a 6-axis system. Angular range is dependent on the measurement distance. Angular range is reduced when the reference mirror is misaligned.

Measurement Optics Specifications, continued

10737L and 10737R Compact Three-Axis Interferometers

Improve positioning accuracy of precision equipment with lower-cost, multi-axis laser measurements. Multi-axis measurements improve accuracy by providing greater control of multi-axis stages. Each linear and angular degree of freedom can be measured and controlled to compensate for mechanical imperfections in the stage's motion. The new Agilent 10737L and 10737R Compact Three-axis Interferometers provide this capability in a more compact, lower-cost package than the 10735A and 10736A Three-axis Interferometers. This allows higher accuracy from multi-axis measurements to be achieved in smaller, lower-cost equipment than was previously possible.

Each 10737L and 10737R makes three linear measurements. Two angular measurements can be calculated from this data. Two of these interferometers used together provide redundant yaw measurements, which allow mirror mapping. Mirror mapping improves accuracy by compensating for mirror flatness deviations.

The 10737L and 10737R also reduce installation time and cost. All three axes are aligned simultaneously in a process similar to alignment of the 10706B High Stability Plane Mirror Interferometer. Both interferometers include built-in remote pickups for 10780F Option 001 Remote Receivers, which simplifies installation and alignment. A simple snap connection for the fiber optic cable quickly connects the receiver to the remote pickups.

The 10737L and 10737R differ only in measurement beam direction; the 10737L turns the beam to the left and the 10737R turns the beam to the right. Both interferometers use the 3-mm beam diameter from the Agilent 5517C Option 003 Laser Head.



Improve positioning accuracy with more compact, lower-cost multi-axis measurements with the 10737L and 10737R compact three-axis interferometers.

Specifications

	10737L & 10737R Specifications	Comparison to 10735A & 10736A
Linear Resolution	5 nm* 0.6 nm**	5 nm* 0.6 nm**
Yaw Resolution	0.35 μ rad (0.07 arc-sec)* 0.04 μ rad (0.01 arc-sec)**	0.2 μ rad (0.04 arc-sec)* 0.025 μ rad (0.005 arc-sec)**
Pitch & Roll Resolution	0.7 μ rad (0.14 arc-sec)* 0.1 μ rad (0.02 arc-sec)**	0.24 μ rad (0.05 arc-sec)* 0.03 μ rad (0.006 arc-sec)**
Yaw Range^{†††}	± 0.44 mrad (± 1.5 arc-min)	± 1 mrad (± 3.4 arc-min) [†] ± 1.5 mrad (± 5.1 arc-min) ^{††}
Pitch & Roll Range^{†††}	± 0.44 mrad (± 1.5 arc-min)	± 1 mrad (± 3.4 arc-min) [†]

* Using 5527A/B, 10885A, 10895A electronics.

** Using 108978 electronics.

[†] Using 6-mm beam diameter.

^{††} Using 9-mm beam diameter.

^{†††} At a distance of 300 mm, maximum measurement mirror angle due to all components (i.e., yaw and pitch or yaw and roll) between the measurement mirror and the interferometer. A six-axis system is assumed.

Linear Range: 10 m (33 ft) total for all three axes
Operating Temperature: 0–40°C (17–23°C to ensure system non-linearity specification)
Thermal Drift Coefficient: 0.1 $\mu\text{m}/^\circ\text{C}$ (40 $\mu\text{in}/^\circ\text{C}$) typical average for each axis
Weight: 490 g (18 oz)

Materials Used:
 Housing: stainless steel and aluminum
 Optics: optical grade glass
 Adhesives: vacuum grade
 Receiver inserts: urethane foam, acetal, 15% glass fill polyester

Installation:
 Uses 3-mm beam available from 5517C Option 003. Requires three 10780F Option 001 Remote Receivers. Compatible with the 10710A Mount.

Measurement (Plane) Mirror Recommendations

Reflectance: 98% at 633 nm at normal incidence.
Flatness: Flatness deviations will appear as measurement errors when the mirror is scanned perpendicular to the beam. Recommended range $\lambda/4$ (0.16 μm or 6 μin) to $\lambda/20$ (0.03 μm or 1.2 μin) dependent on accuracy requirements.

Optical Surface Quality:
 60–40 per Mil 0-13830.

Dimensions

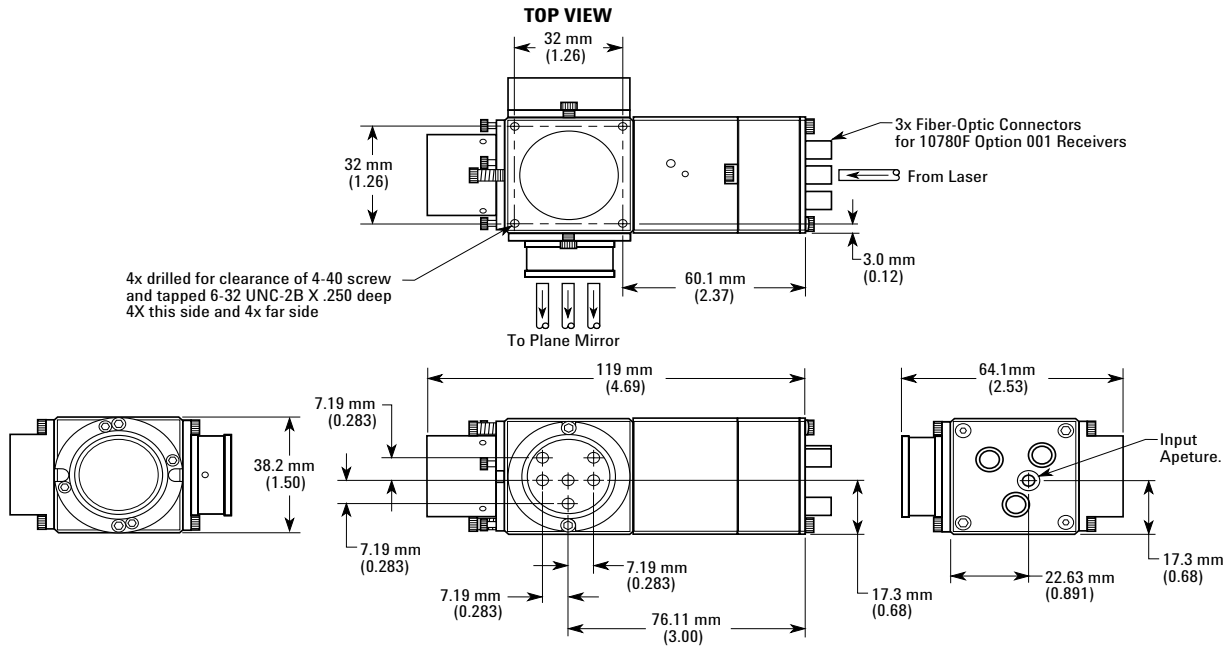

The Agilent 10737L. The dimensions of the 10737R are identical.

Measurement Optics Specifications, continued

Additional features that increase accuracy and decrease cost

- *Wide angle range*
- *Monolithic optics*
- *Guaranteed interaxis parallelism*
- *Prealigned fiber-optic remote receiver mounting*
- *Referenced optics*
- *Kinematic Installation*

The 10735A and 10736A are three-axis optical benches in single packages

The 10735A and 10736A Three-axis Interferometers put the functionality of an optical bench with multiple beam benders, beam splitters, and three interferometers in a single high-performance package. This eliminates expensive, time-consuming interaxis setup and alignment. The interferometers split an incoming laser beam into three beams to measure linear distance, pitch, and yaw; or linear distance, roll, and yaw. Custom Agilent factory fixtures and measuring equipment align and lock the parallel beams to guaranteed specifications for greater stability and accuracy than is practical with discrete components. This gives you greater overall system performance.

Multiaxis installation simplified

All axes are referenced to the interferometer's mounting surface for easy kinematic installation onto a user-supplied reference surface. This makes installation as easy as sliding the interferometer into place and bolting it down. The interferometers differ in the beam pattern they produce on the measurement mirror, providing flexibility in system design.

Three-axis interferometers provide the highest angular performance available

The 10735A and 10736A provide the highest resolution, widest angular range, and most accurately aligned three-axis interferometers available off-the-shelf. The high angular resolution gives you greater control over your multiaxis stage, enabling superior grid accuracy in lithography applications. The wide angular measurement range, with a 9-mm laser beam, allows both global and site-by-site stage correction under interferometric control. This helps to achieve high positioning accuracy without degrading throughput.



The Agilent 10735A and 10736A replace three interferometers and multiple beam benders and beam splitters with a rigid, high-performance package.

10735A/10736A Three-axis Interferometers

Use: Multiaxis applications where linear and angular control of the stage is required. The Agilent 10735A and 10736A provide three linear measurements. Two angular measurements can be calculated from this data. When an interferometer is placed along the X axis, yaw (q_z), and pitch (q_y) can be derived in addition to linear (X) displacement. When it is placed on the Y axis, yaw (q_z), and roll (q_x) can be derived in addition to linear (Y) displacement. Redundant yaw is useful when mapping measurement mirrors, which provides improved accuracy. The 10735A and 10736A differ in their measurement beam patterns (see drawing). Agilent 10736A Option 001 provides a beam bender for fixed compensation axis.

Specifications

Weight: 5.5 kg (12 lbs)
 Axes: 3 linear axes which provide linear (X), pitch, and yaw; or linear (Y), roll, and yaw.
 Available Beam Diam.: 3/6/9 mm
 Thermal Drift Coefficient (Average):
 Axes 1 & 2: 40 nm (1.6 μ in) /°C
 Axis 3: 100 nm (3.9 μ in) /°C
Resolution*
 Linear: 0.6 nm
 Yaw: 0.024 μ rad (0.005 arc-sec)
 Pitch/roll: 0.03 μ rad (0.006 arc-sec)
Angular Range (at 300 mm displacement)**
 Pitch/roll: ± 1 mrad (± 3.4 arc-min)
 Yaw (for 6-mm beams): ± 1 mrad (± 3.4 arc-min)
 Yaw (for 9-mm beams): ± 1.5 mrad (± 5.1 arc-min)
Parallelism (Measurement beams):
 Axes 1 & 2: <40 μ rad (8 arc-sec)
 Axes 1 & 3: <50 μ rad (11 arc-sec)

10735A/10736A Installation Recommendations

Installation and Alignment: Kinematic installation procedure requires three referenced pins mounted onto a referenced surface. See "Laser and Optics Users Manual" for complete installation procedure.

Interaxis Alignment: All internal optics are referenced to the mounting surface and prealigned.

Receivers: Agilent 10780F Fiber Optic Remote Receivers.

Receiver Alignment: Self aligning when mounted to interferometer.

Measurement (Plane) Mirror Recommendations: Same as 10706A/B; see page 11.

NOTE:
Dimensions given
in millimeters and (inches)

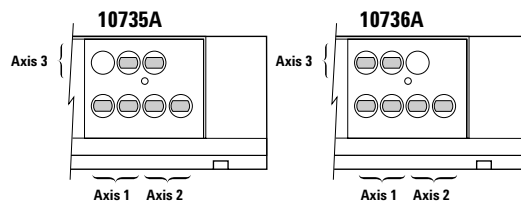
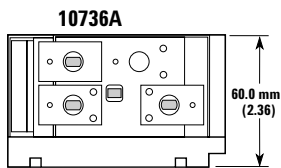
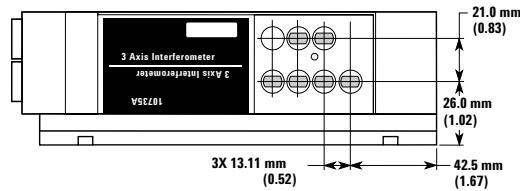
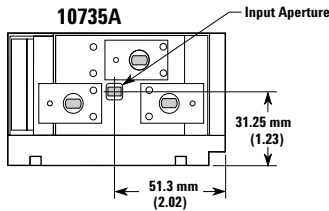
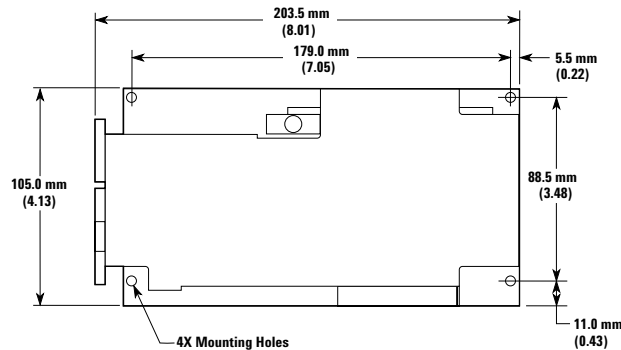

Measurement Beam Patterns

* Resolution is dependent on the electronics used. These specifications are for the Agilent 10897B electronics.

** Angular range is the maximum angle between the measurement mirror and the interferometer for a 6-axis system. Angular range is dependent on the measurement distance. Both angles (pitch and yaw or roll and yaw) can be at the angular limit concurrently.

Measurement Optics Specifications, continued

Wavelength Tracker

10717A Wavelength Tracker

Use: Tracks changes in the air's index of refraction to optically compensate for environmental changes.

Weight: 1.7 kg (3.7 lb)

Kinematic Mounting:

Angular Adjustment Range (at nominal position):

Pitch: $\pm 1^\circ$

Yaw: $\pm 1^\circ$

Translation Adjustment Range (at nominal position):

Vertical: ± 3 mm (0.12 in)

Horizontal: ± 3 mm (0.12 in)

Mounting Hardware Quantity:

3,10-32 UNF2A Screws

Minimum Mounting Clearance Required:

3 mm (0.12 in) around perimeter.

Calibration: Not Required.

Interface: Measurement receiver, cable, and appropriate electronics required.

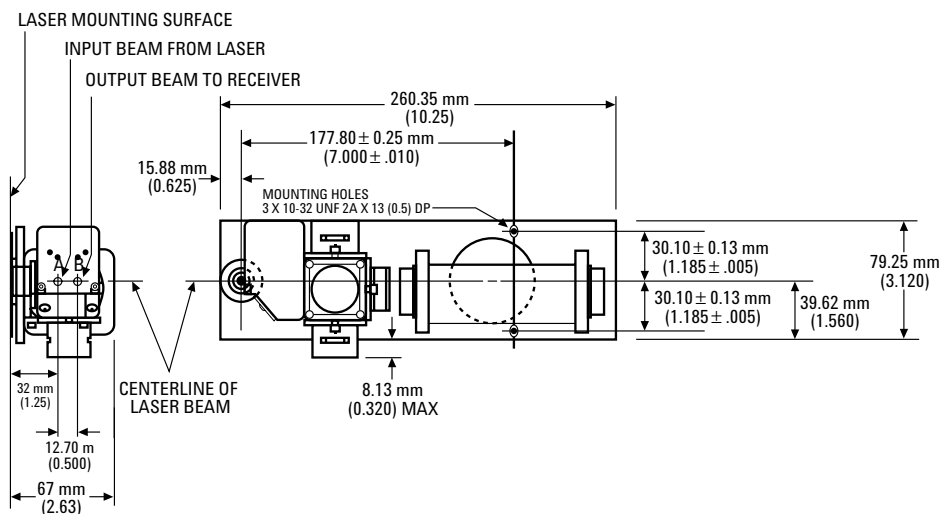
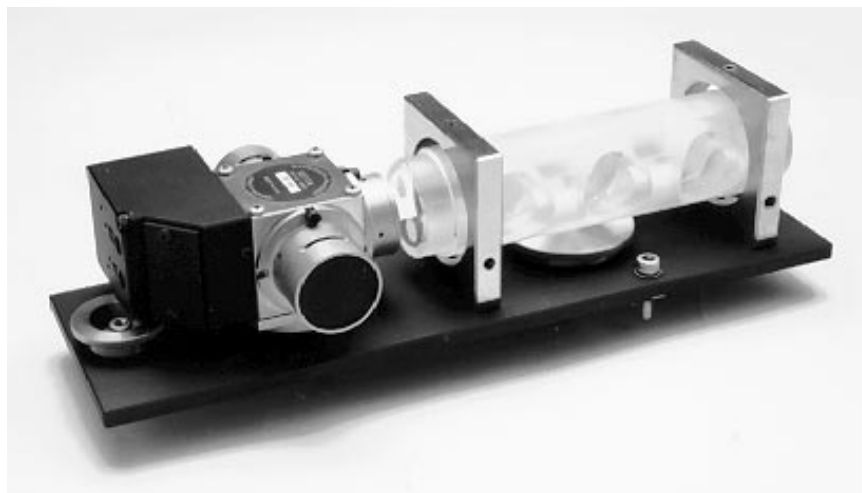

Accessory Specifications

Optics mounts can make alignment faster and easier, and are available for most optics. Detailed specifications are below.

Optics Mounts

10710A Adjustable Mount

Use: Mount for Agilent 10700A, 10701A, 10705A, and 10707A

Weight: 88.2 g (3.2 oz)

Angular Adjustment Range:

Yaw: $\pm 8^\circ$

Tilt: $\pm 8^\circ$



10710A

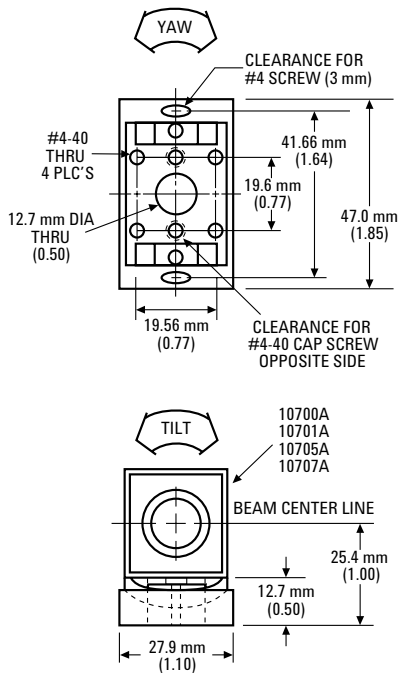

10711A Adjustable Mount

Use: Mount for Agilent 10702A, 10706A/B, 10715A, and 10716A

Weight: 141.1 g (5 oz)

Angular Adjustment:

Yaw: $\pm 5^\circ$

Tilt: $\pm 5^\circ$



10711A

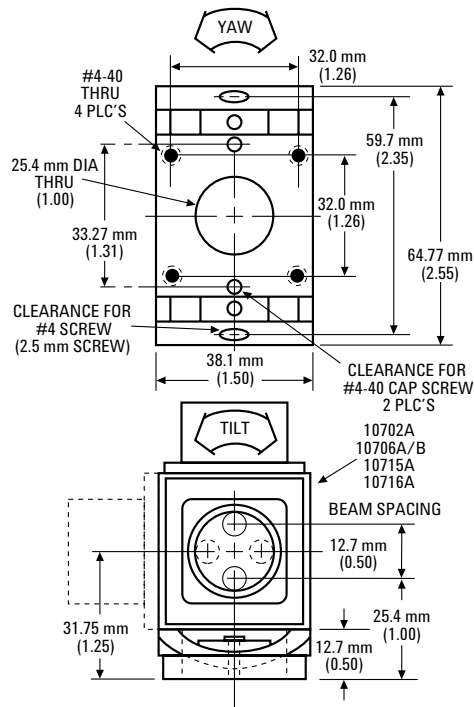

10722A Plane Mirror Converter

Use: With an additional 10703A, the 10722A can be used to convert a 10702A Linear Interferometer into a 10706A Plane Mirror Interferometer. With an additional 10723A, the 10722A can be used to convert a 10702A into a 10706B.

Weight: 35.5 g (1.3 oz)



10723A High Stability Adapter

Use: If you already use the 10706A, you can easily convert it to a 10706B with the 10723A High Stability Adapter. With the 10723A you can obtain the much higher thermal stability of the 10706B at nominal cost and effort.

Weight: 49 g (1.7 oz)



Receiver Specifications

Two different measurement receivers are available to give you design flexibility and maximum system performance. One receiver is required for each measurement axis (including wavelength tracker). The Agilent 10780C affords the highest sensitivity and lowest cost. The 10780F provides slightly less sensitivity, but can improve system performance by enabling you to mount heat-dissipating receiver electronics away from the measurement area. Hence, higher measurement stability and the resulting accuracy and repeatability are obtained. The fiber-optic cable used to attach the remote sensor to the receiver electronics allows design flexibility and easier access to the receiver gain adjustment.

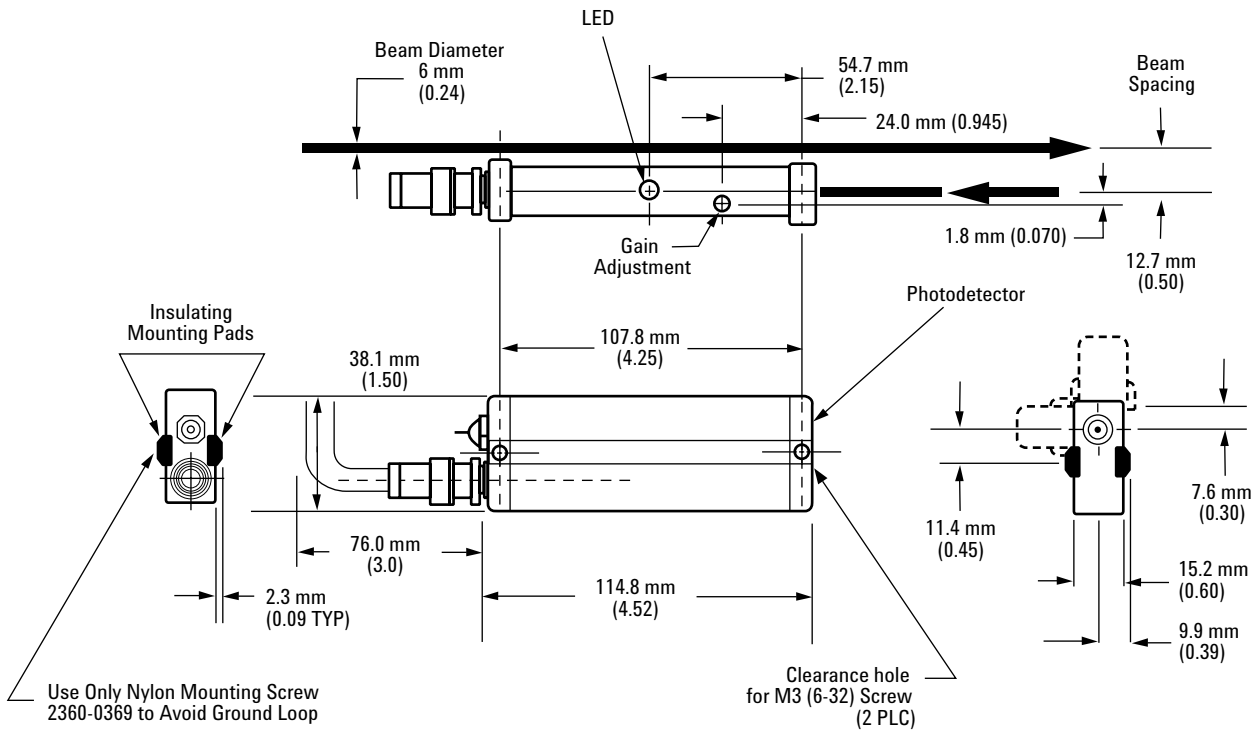
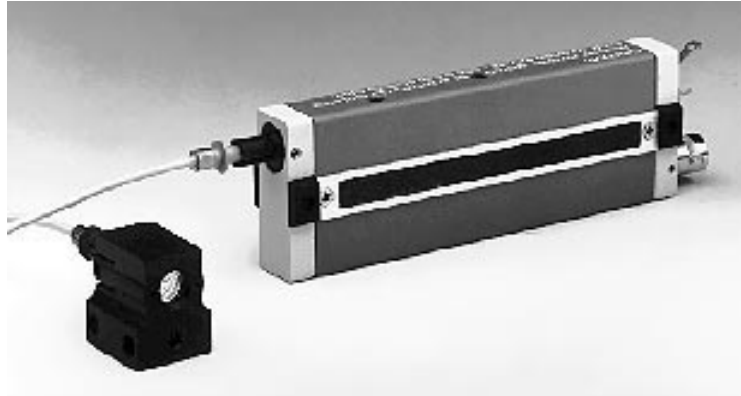

Agilent 10780C Receiver

10780C Receiver and 10780F Remote Receiver Specifications

Typical Power Requirements:

+15 volts at 136 mA

Maximum Sensitivity:

1.5 μ W (10780C)

2.2 μ W (10780F with 2-m cable)

(10780F becomes 5.0 μ W with a 10-m fiber cable.)

Heat Dissipation:

0.0 W for remote sensor

2.0 W typical for receiver

Output Signal:

Differential square wave at Doppler-shifted split frequency (100 kHz to 7.2 MHz).

Fiber-optic Cable Length (10780F):

2 m standard

10 m maximum recommended

Alignment Tolerances:

Roll: ± 3 degrees

Pitch: ± 1 degree

Yaw: ± 1 degree

(10780F is self aligning when mounted to the 10715A, 10716A, 10717A, 10719A, 10721A, 10735A, and 10736A.)

Weight:

136 g (4.8 oz) for 10780C

126 g (4.5 oz) for 10780F

26 g (0.9 oz) for remote sensor with 2-m cable

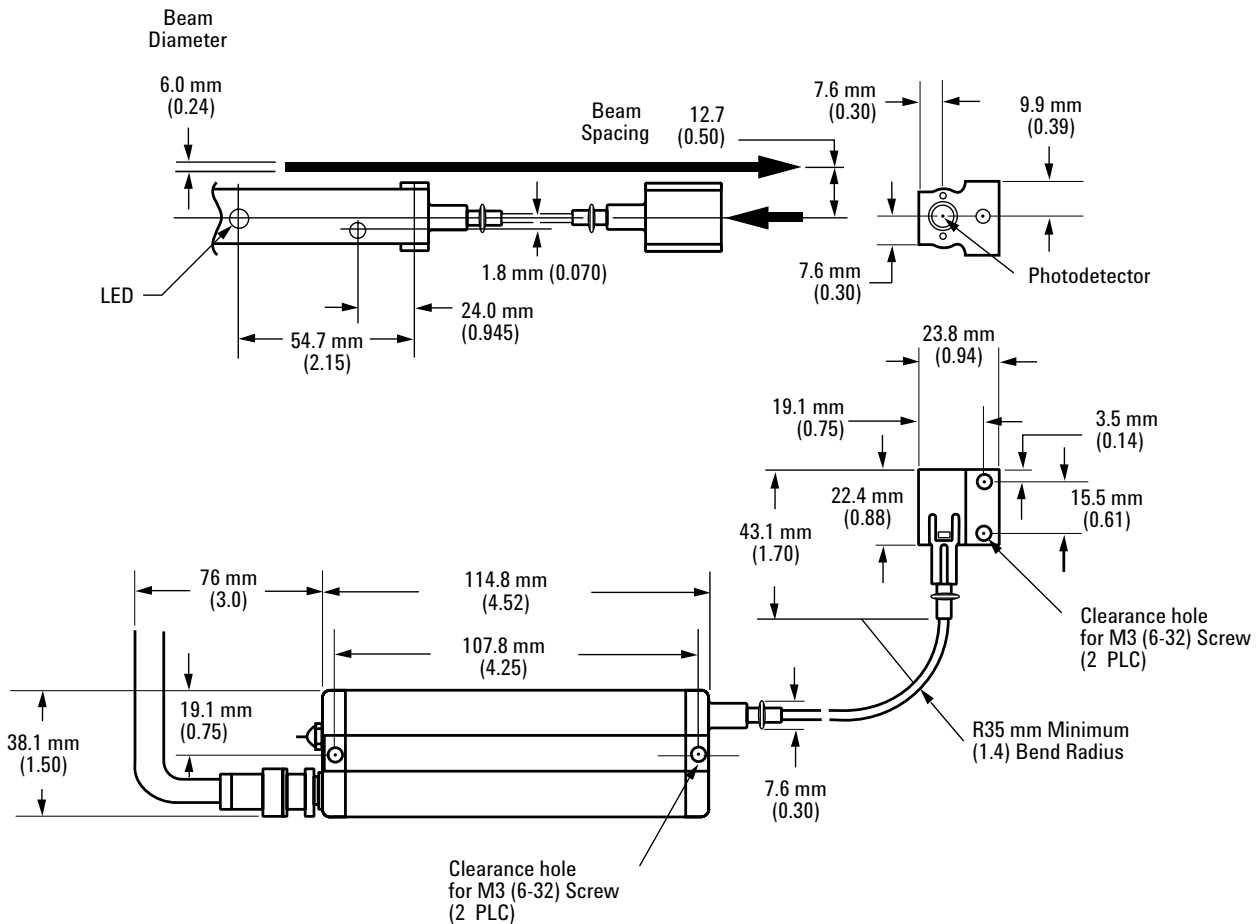

Agilent 10780F Remote Receiver

Optics and Laser Head Configuration Guide

Use this configuration guide to design your Agilent laser interferometer positioning system. Generally you will first refer to the appropriate electronics data sheet and choose the electronics accordingly. Then

you select your laser head based on size and axis velocity requirements. Next, sketch your optical configuration. From this layout, determine your optics needs.

Two additional years of return-to-Agilent service are available at purchase for all laser heads and electronics as Option W30. Contact your local Agilent sales representative for details.

Component Needs Comments

Laser Head

One required per system

5517A	Laser Head, lowest velocity, largest size
5517B	Laser Head, 25% more velocity, small size
5517C	Laser Head, 75% more velocity, small size
Opt. 003	3-mm beam diameter for use with 10719A and 10721A
Opt. 009	9-mm beam diameter
5517D	Laser Head, highest velocity, small size
5501B	Laser Head, lowest velocity, small size, interface same as 5501A

Factory Calibration to MIL-STD 45662 is available at extra cost, and may be specified in the order.

Directing Optics

Order as required to manipulate beam path to your configuration

10700A	33% Beam Splitter
10701A	50% Beam Splitter
10707A	Beam Bender
10567A	Dual Beam Splitter—useful in vacuum
10725A	9-mm Laser Beam Splitter
10726A	9-mm Laser Beam Bender
10728A	9-mm Laser Beam Plane Mirror

Measurement Optics

1 interferometer-plus-reflector pair required per axis

10702A	Linear Interferometer
Opt. 001	Windows—required if interferometer is the moving component
10703A	Reflector—paired with 10702A
10704A	Reflector—paired with 10705A
10705A	Single Beam Interferometer
10706B	High Stability Plane Mirror Interferometer
10713B	One-inch bare cube corner
10713C	0.5-inch bare cube corner
10713D	0.25-inch bare cube corner
10715A	Differential Interferometer
Opt. 001	Turned Configuration
10716A	High Resolution Interferometer
Opt. 001	Turned Configuration
10724A	Plane Mirror Reflector
10719A	One-axis Differential Interferometer, requires 3-mm beam
10721A	Two-axis Differential Interferometer, requires 3-mm beam
10735A	Three-axis Interferometer
10736A	Three-axis Interferometer
Opt. 001	Adds beam bender
10737L	Compact Three-axis Interferometer (Left)
10737R	Compact Three-axis Interferometer (Right)

Measurement Optics Summary

	10702A	10705A	10706B	10715A	10716A
Application	General Purpose	Low-mass, Limited Space	Plane Mirror	High Accuracy Plane Mirror	High Resolution Plane Mirror
Optics Resolution	$\lambda/2$ (316.5 nm)	$\lambda/2$ (316.5 nm)	$\lambda/4$ (158.25 nm)	$\lambda/4$ (158.25 nm)	$\lambda/8$ (79 nm)
System Resolution*	$\lambda/64$ (10 nm)	$\lambda/64$ (10 nm)	$\lambda/128$ (5 nm)	$\lambda/128$ (5 nm)	$\lambda/256$ (2.5 nm)
Beam Separation	12.7 mm (1/2 in)	N/A single beam	12.7 mm (1/2 in)	12.7 mm (1/2 in)	12.7 mm (1/2 in)
Reflector	10703A	10704A	10724A	10724A	10724A
Reflector Weight	42 g (1.5 oz)	10.5 g (0.4 oz)	50 g (1.8 oz)	50g (1.8 oz)	50g (1.8 oz)
Mount Used	10711A	10710A	10711A	10711A	10711A

	10717A	10719A	10721A	10735A	10736A
Application	Wavelength of Light Compensation	One-axis Differential Measurements (Plane Mirror)	Two-axis Differential Measurements (Plane Mirror)	Three-axis Measurements (distance, pitch, yaw) (Plane Mirror)	Three-axis Measurements (distance, pitch, yaw) (Plane Mirror)
Optics Resolution					
Linear	$\lambda/4$ (158.25 nm)	$\lambda/4$ (158.25 nm)	$\lambda/4$ (158.25 nm)	$\lambda/4$ (158.25 nm)	$\lambda/4$ (158.25 nm)
System Resolution*					
Linear	$\lambda/128$ (5 nm)	$\lambda/128$ (5 nm)	$\lambda/128$ (5 nm)	$\lambda/128$ (5 nm)	$\lambda/128$ (5 nm)
Pitch		0.26 μ rad (0.054 arc-sec)	0.4 μ rad (0.08 arc-sec)	0.24 μ rad (0.05 arc-sec)	0.24 μ rad (0.05 arc-sec)
Yaw			N/A	0.2 μ rad (0.04 arc-sec)	0.2 μ rad (0.04 arc-sec)
Beam Separation	N/A	see drawing	see drawing	see drawing	see drawing
Reflector	Integral	Custom	Custom	Custom	Custom
Reflector Weight	N/A	Custom	Custom	Custom	Custom
Mount Used	Integral	Custom	Custom	Custom	Custom

* When used with the Agilent 5527B Laser Positioning Transducer System, 10885A PC Axis Board, or 10895A Laser Axis Board for VMEbus. System resolution is improved by a factor of 2 when using the Agilent 10889B PC Servo Axis Card. The 10897B improves system resolution by a factor of 8.

Specifications throughout this document describe warranted performance. Supplemental characteristics (indicated by TYPICAL or AVERAGE) are intended to provide nonwarranted performance information useful in general application.

Example Configurations

Example 1—Single Axis System for Servo-Track Writing

- 1- 5517B/C Laser Head
- 1- 10705A Single Beam Interferometer
- 1- 10704A Reflector (or use bare corner cube)
- 1- 10780C/F Receiver
- 1- 10710A Optics Mount

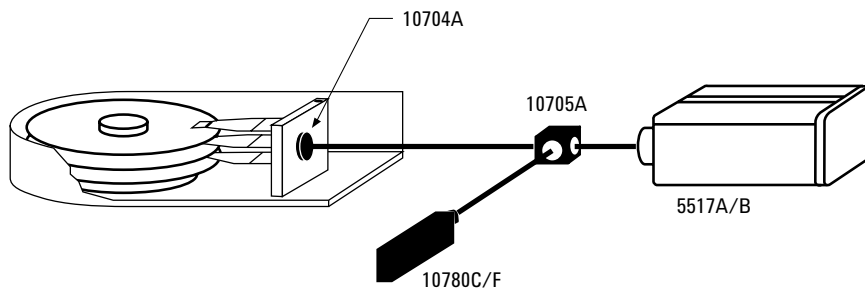

Example 2—Multiaxis System for a Coordinate Measuring Machine

- 1- 5517B Laser Head
- 3- 10702A Linear Interferometer
- 3- 10703A Retroreflector
- 2- 10700A 33% Beamsplitter
- 1- 10701A 50% Beamsplitter
- 3- 10707A Beam Bender
- 1- 10717A Wavelength Tracker
- 4- 10780C/F Receiver
- 6- 10710A Adjustable Mount
- 3- 10711A Adjustable Mount

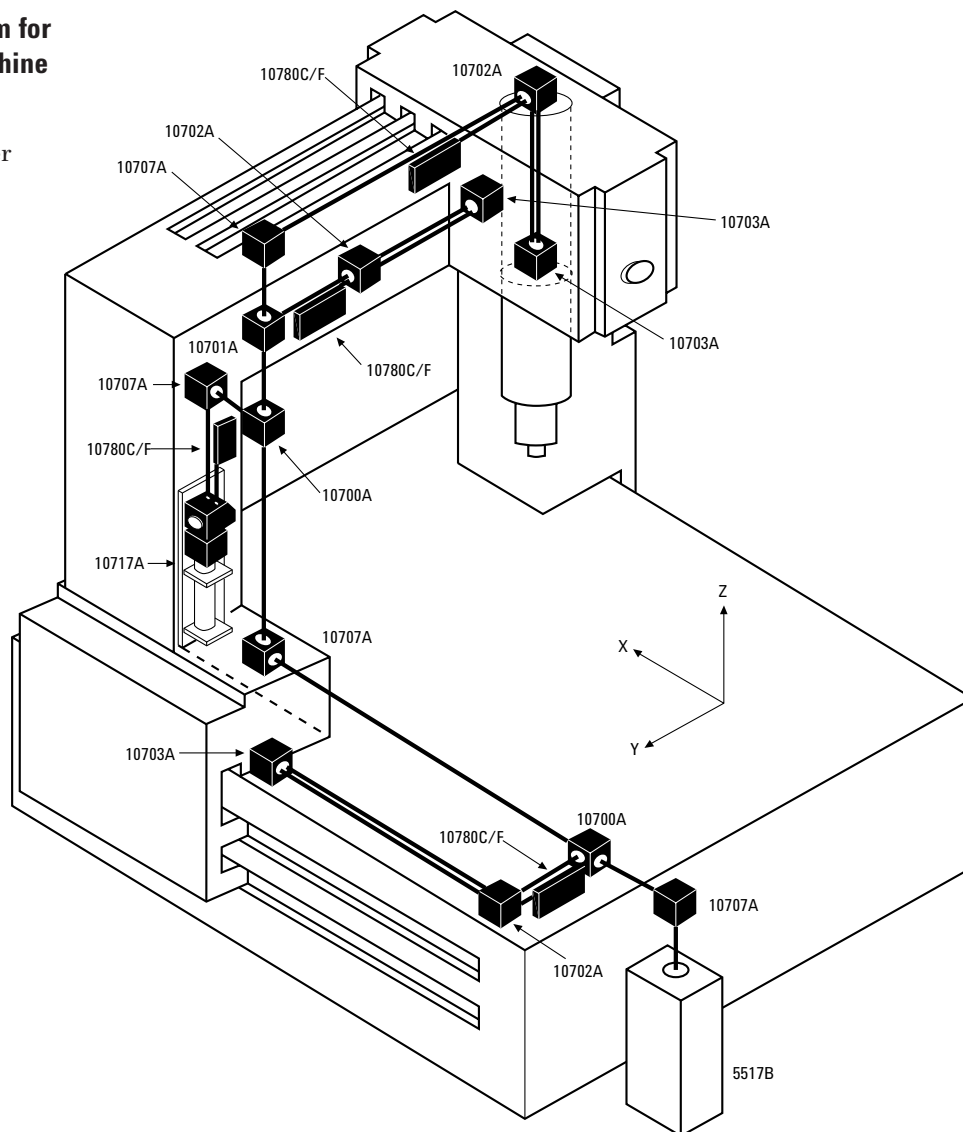

Example 3—Multiaxis System for a Precision X-Y Stage

- 1- 5517C Laser Head
- 3- 10701A 50% Beam Splitter
- 3- 10706B High-Stability Plane Mirror Interferometer
- 1- 10707A Beam Bender
- 1- 10717A Wavelength Tracker
- 4- 10780C/F Remote Receiver
- 4- 10710A Optics Mount
- 3- 10711A Optics Mount

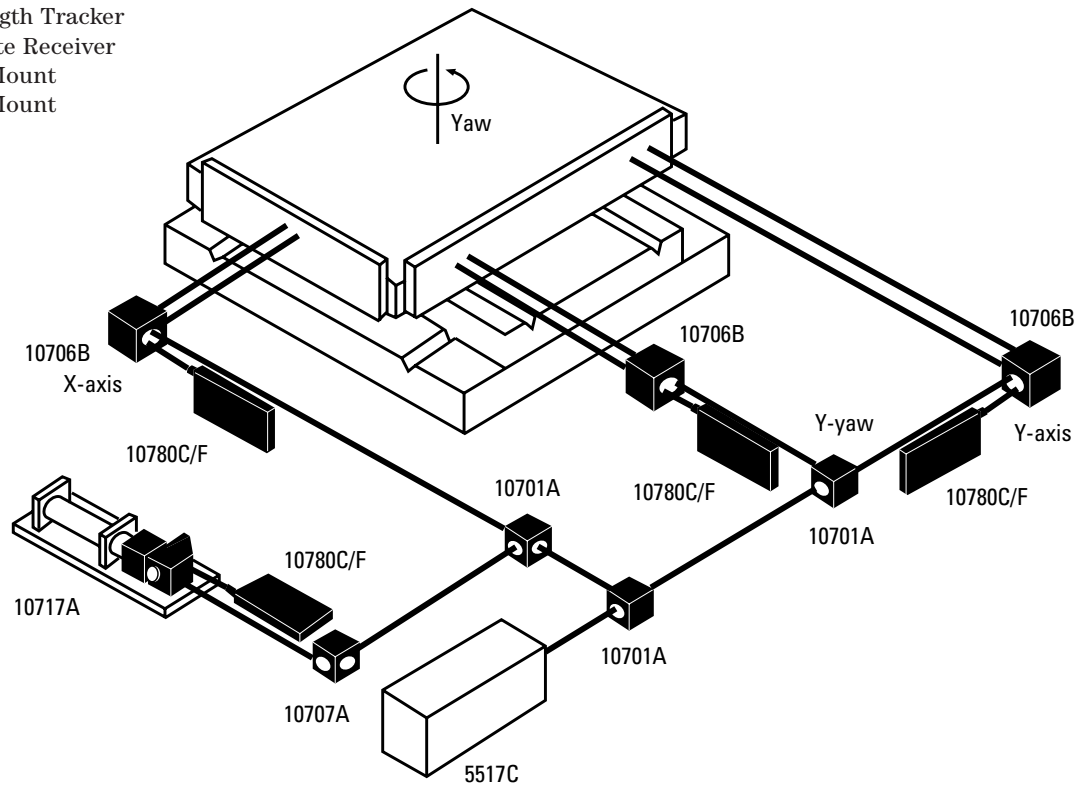

Multiaxis System for a Precision X-Y Stage as Used in IC Fabrication

Example Configurations, continued

Example 4—Three-axis X-Y Stage Laser Positioning System with Column Referencing

- 1- 5517C Opt. 003 3-mm Laser Head
- 1- 10701A 50% Beam Splitter
- 1- 10707A Beam Splitter
- 1- 10719A One-axis Differential Interferometer
- 1- 10721A Two-axis Differential Interferometer
- 3- 10780F Remote Receiver
- 3- 10710A Adjustable Mount

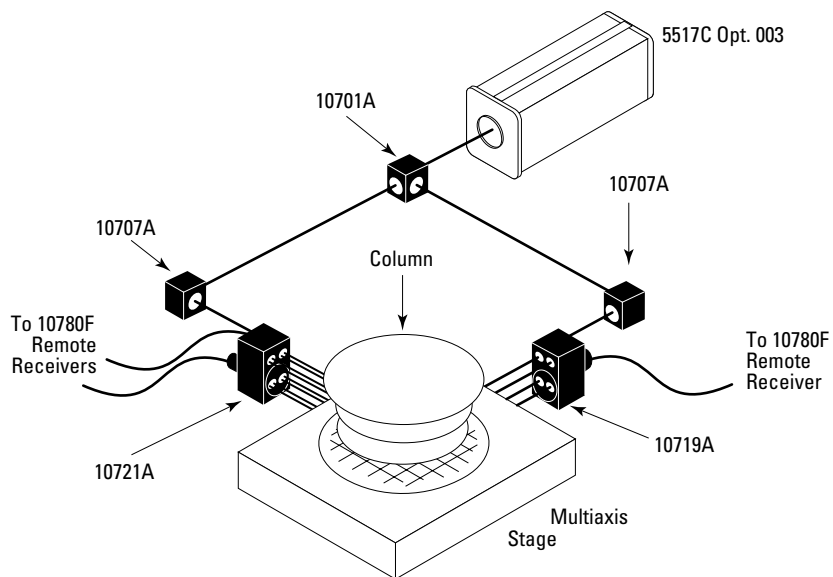

Example 5—Five-axis X-Y Stage Laser Positioning System

- 1- 5517C Opt. 009 9-mm Laser Head
- 1- 10725A 9-mm Laser Beam Splitter
- 2- 10726A 9-mm Laser Beam Bender
- 2- 10736A Three-axis Interferometer
- 6- 10780F Remote Receiver

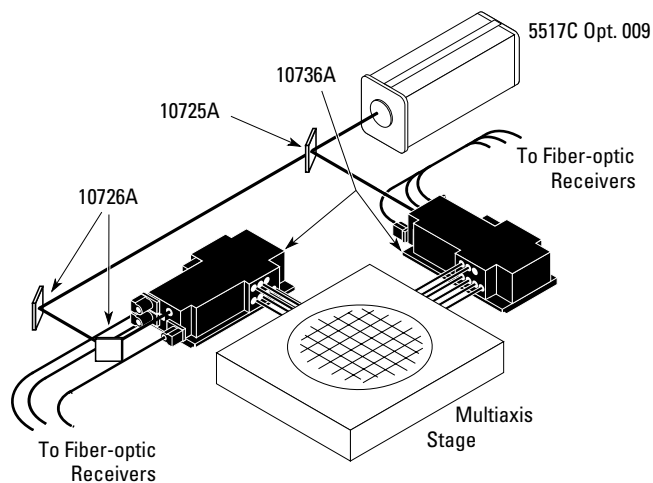

Agilent Technologies' Test and Measurement Support, Services, and Assistance

Agilent Technologies aims to maximize the value you receive, while minimizing your risk and problems. We strive to ensure that you get the test and measurement capabilities you paid for and obtain the support you need. Our extensive support resources and services can help you choose the right Agilent products for your applications and apply them successfully. Every instrument and system we sell has a global warranty. Support is available for at least five years beyond the production life of the product. Two concepts underlie Agilent's overall support policy: "Our Promise" and "Your Advantage."

Our Promise

"Our Promise" means your Agilent test and measurement equipment will meet its advertised performance and functionality. When you are choosing new equipment, we will help you with product information, including realistic performance specifications and practical recommendations from experienced test engineers. When

you use Agilent equipment, we can verify that it works properly, help with product operation, and provide basic measurement assistance for the use of specified capabilities, at no extra cost upon request. Many self-help tools are available.

Your Advantage

"Your Advantage" means that Agilent offers a wide range of additional expert test and measurement services, which you can purchase according to your unique technical and business needs. Solve problems efficiently and gain a competitive edge by contracting with us for calibration, extra-cost upgrades, out-of-warranty repairs, and on-site education and training, as well as design, system integration, project management, and other professional services. Experienced Agilent engineers and technicians worldwide can help you maximize your productivity, optimize the return on investment of your Agilent instruments and systems, and obtain dependable measurement accuracy for the life of those products.

By internet, phone, or fax, get assistance with all your test and measurement needs.

Online Assistance

www.agilent.com/find/assist

Phone or Fax
United States:
(tel) 1 800 452 4844

Canada:
(tel) 1 877 894 4414
(fax) (905) 282 6495

Europe:
(tel) (31 20) 547 2323
(fax) (31 20) 547 2390

Japan:
(tel) (81) 426 56 7832
(fax) (81) 426 56 7840

Latin America:
(tel) (305) 269 7500
(fax) (305) 269 7599

Australia:
(tel) 1 800 629 485
(fax) (61 3) 9210 5947

New Zealand:
(tel) 0 800 738 378
(fax) (64 4) 495 8950

Asia Pacific:
(tel) (852) 3197 7777
(fax) (852) 2506 9284

Product specifications and descriptions in this document subject to change without notice.

Copyright © 2009 Agilent Technologies
Printed in U.S.A. 02/09
5964-6190E



Agilent Technologies